

SOLARWATT M270-72 GET AK

GLASS-FOIL-SOLAR-MODULE

ENGLISH

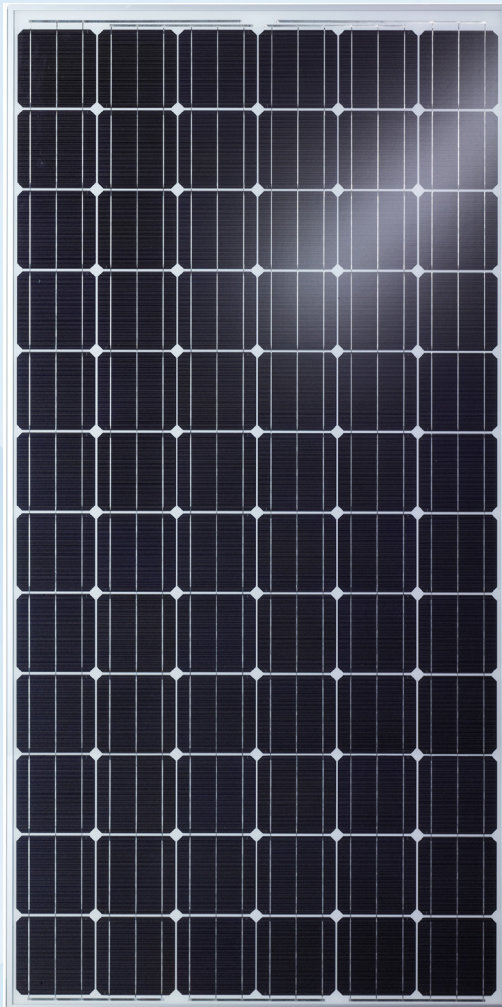

SOLARWATT modules supply the highest yield through optimally matched materials and sorting in tight performance classes. Tested source material, the most careful processing and the strictest test procedures guarantee the longevity of the modules. SOLARWATT modules are exclusively manufactured in Germany.

The solar module SOLARWATT M270-72 GET AK for grid-connected plants connects SOLARWATT's familiar high quality with efficient installation and an outstanding cost-performance ratio.

- » monocrystalline solar cells with an efficiency of up to 18%
- » frame with hollow chamber profile and drainage opening
- » high mechanic stability and torsional stiffness
- » insulated and against reverse polarity protected connectors
- » positive classification range (-0 Wp to + 5 Wp)
- » Max. system voltage 1000 V
- » cells and used materials are tested disengaged on the basis of test routines
- » quality test during all manufacturing steps
- » 5 years warranty acc. to Special Warranty Conditions
- » resource-conserving, patented packing system QUICKSTAXX®



SOLARWATT AG
Maria-Reiche-Str. 2a
01109 Dresden, Germany
Tel. +49 351 8895-0
Fax +49 351 8895-111
info@solarwatt.de
www.solarwatt.de

CERTIFIED ACC. TO:
DIN EN ISO 9001 und 14001

[NOMENCLATURE OF NAMES OF SOLARWATT MODULES]

M

TYPE OF CELLS

A = amorphous silicon
M = monocrystalline silicon
P = polycrystalline silicon

270

BENCHMARK FOR MODULE PERFORMANCE

Nominal Power and performance class are specified in the data sheet

-

72

NO. OF CELLS

GET

LAYER KONSTRUKTION

E = EVA
G = Glass
K = Synthetics
T = Tedlar-composite film

A

FRAME

A = Aluminium
E = Stainless Steel
L = Laminate
(without frame)

K

CONNECTION

B = Ribbon
D = Box
K = Cable

SOLARWATT M270-72 GET AK

TECHNICAL DATA

SOLARWATT APPOINTED DEALER:



Subject to change without notice.

DIMENSIONS

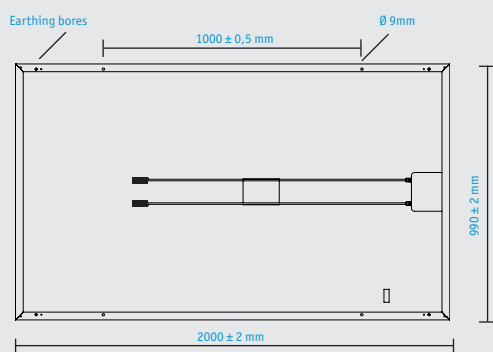

GENERAL DATA

Module Technology	Glass-Foil-Laminate; Aluminium Frame
Cover material	High transparent solar glass (tempered), 4 mm
Encapsulation	EVA-Solar Cells-EVA
Back material	Tedlar-Polyester-Tedlar, white
No. and Type of Cells	72 monocrystalline solar cells
Dimensions of Cells	156 x 156 mm
Cables	Junction box with tyco plug connector cables 2 x 1,00 m/4 mm ²
Bypass-Diodes	3 pcs.
Application Class	Class A at IEC 61730
Dimensions (LxWxH)	2000 x 990 x 50 mm
Weight	29 kg
Max. System Voltage	1000 V
IP Protection Level	IP 65
Mechanical Ratings	Suction pressure of 2400 Pa approved (Wind speed 130 km/h with safety factor 3) Load of 5400 Pa approved
Qualifications	IEC 61215 Ed.2, IEC 61730 (incl. Safety Class II)

ELECTRICAL DATA (STC)

STC: Standard Test Conditions: measurement conditions: Radiation strength 1000 W/m², spectral distribution AM 1.5, temperature 25 °C, in accordance with EN 60904-3

Specification	SOLARWATT M270-72 GET AK			
Nominal Power P_N	275 Wp	280 Wp	285 Wp	290 Wp
Nominal Voltage U_{mpp}	35,7 V	35,8 V	35,9 V	36,1 V
Nominal Current I_{mpp}	7,71 A	7,82 A	7,94 A	8,02 A
Open Circuit Voltage U_{OC}	43,7 V	43,7 V	43,8 V	43,9 V
Short Circuit Current I_{SC}	8,15 A	8,17 A	8,18 A	8,20 A
I_R*	20 A			

Measuring tolerances P_{max} ±5 %;* Reverse current power rating: Operation of the modules with an external power source is only permitted with a string fuse with a release current of < 2 x I_{SC} @ NOCT.Reduction in the module efficiency with reduction in radiation strength of 1000 W/m² to 200 W/m² (25 °C): 4^{±2}% (relative) / -0,6^{±0,3}% (absolute).

ELECTRICAL DATA (NOCT)

NOCT: Normal Operation Cell Temperature, measurement conditions: Radiation strength 800 W/m², AM 1.5, temperature 20 °C, wind speed 1m/s, electrical open-circuit operation

Specification	SOLARWATT M270-72 GET AK			
Nominal Power P_N	198 W	202 W	205 W	208 W
Nominal Voltage U_{mpp}	32,5 V	32,6 V	32,7 V	32,9 V
Open Circuit Voltage U_{OC}	40,5 V	40,5 V	40,6 V	40,7 V
Short Circuit Current I_{SC}	6,56 A	6,58 A	6,58 A	6,60 A

CHARACT. LINE

Voltage charact. line with different irradiations

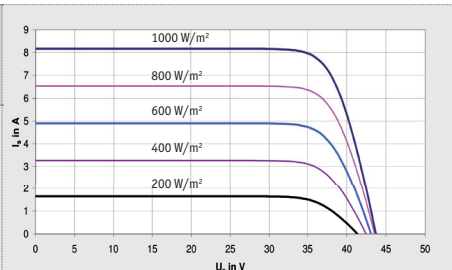

THERMAL FEATURES

Operating Temperature Range	-40 ... +80 °C
Ambiente Temperature Range	-40 ... +45 °C
Temperature Coefficient of P_N	-0,50%/K
Temperature Coefficient of U_{OC}	-0,37%/K
Temperature Coefficient of I_{SC}	0,03%/K
NOCT	45 °C